

SKORPION ZINC: OPTIMISATION AND INNOVATION

J. Gnoinski

jgnoinski@skorpionzinc.com.na

Namzinc (Pty) Ltd, Private Bag 2003, Rosh Pinah
Namibia

ABSTRACT

The Skorpion process comprises three processing steps, atmospheric leaching in sulphuric acid, zinc solvent extraction and electrowinning to produce special high grade zinc. The major mode of impurity transfer was attributed to crud runs in the solvent extraction circuit. Crud may be described as a heterogeneous, partly inorganic, partly organic mass of material which accumulates predominantly at the interface between organic and aqueous solutions. The paper describes the route causes of the crud formation in the solvent extraction circuit and optimisation strategies which are being followed to prevent impurity excursions in electrowinning.

Keywords: zinc oxide, solvent extraction, crud formation, colloidal silica

1.0 Introduction

The Skorpion process was developed to treat a complex non-sulphide oxide ore body using atmospheric leaching followed by solvent extraction and electrowinning of zinc (1,2,3) . Sauconite is the largest contributor to the zinc grade with lesser amounts of zinc hydroxides. The gangue minerals are mainly quartz, K-feldspar and muscovite mica. The plant operation achieves an annualised zinc production of 150 000 tonnes special high grade zinc. The choice of SX technology was dictated by the need to upgrade the zinc tenor for electrowinning, to reject dissolved halides and to minimise soluble losses of zinc in the filtration step.

The refinery was commissioned during the first half of 2003 and ramped up to full production in 2005. The full production run was interrupted during 2005 and August 2006 due to hydrogen fires in electrowinning caused by the transfer of significant concentrations of impurities from the solvent extraction circuit, namely nickel and copper, into the electrolyte solution. The major mode of impurity transfer was attributed to crud runs in the solvent extraction circuit. Crud may be described as a heterogeneous, partly inorganic, partly organic mass of material which accumulates predominantly at the interface between organic and aqueous solutions.

The paper describes the route causes of the crud formation in the solvent extraction circuit and optimisation strategies which are being followed to prevent impurity excursions in electrowinning.

2.0 Process chemistry

2.1 Leaching

Leaching of zinc oxide ores by sulfuric acid are generally described in terms of the following reaction equations:

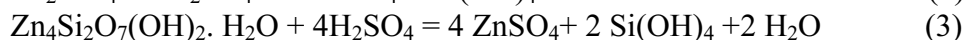
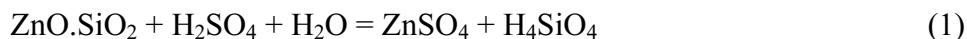

Leaching is carried it out in a series of agitated tanks at about 50°C. The final pH is maintained between 1.8 - 2.0 to maximise stability of colloidal silica. After leaching the pH is raised to 4.0 to ensure to maximise agglomeration and the formation of precipitate.

Dissolved siliceous species, namely, $\text{Si}(\text{OH})_4$ (monosilicic acid) remain in solution under conditions, where its solubility is not exceeded. Depending on pH, temperature and dissolved salts concentrations siliceous species will tend to polymerise to form colloidal silica. These siliceous polymers, sized from 1 nm to 1000 nm, have a massive surface area, but are still small enough to be unaffected by gravity. Colloidal-sized, polysilicic molecules can cause serious problems in a solvent extraction (SX) system by stabilising emulsions. The formation of colloidal silica is irreversible and follows a dehydration process;

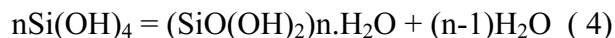

2.2 Solvent extraction

During solvent extraction the organic extractant used is 40% v:v di-2-ethyl hexyl phosphoric acid (D2EHPA, symbolized as RH) diluted in the solvent ESCAID 100. The extraction of zinc is by cation exchange:

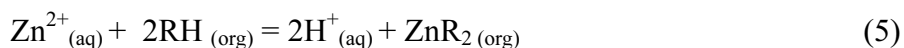

The organic phase is stripped of zinc using spent electrolyte:

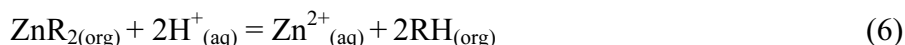

The extraction versus pH curves provide an indication of the selectivity of the organic extractant under different conditions. A typical E-pH curve measured is shown in Figure 1 (4). From reaction (5) it is seen that the acidity of the aqueous phase increases as the extraction proceeds, with two protons released for each metal ion extracted. For typical Skorpion operating conditions of 30 g/l Zn in the PLS and 10 g/l Zn in the raffinate, this corresponds to approximately 30 g/l H_2SO_4 being generated across the extraction circuit. The general order of selectivity with increasing pH in this system is (4):

$\text{Fe}(\text{III}) < \text{Zn} < \text{Ca} < \text{Al}(\text{III}) < \text{Mn} < \text{Cd} \sim \text{Cu} < \text{Mg} < \text{Co} < \text{Ni}$.

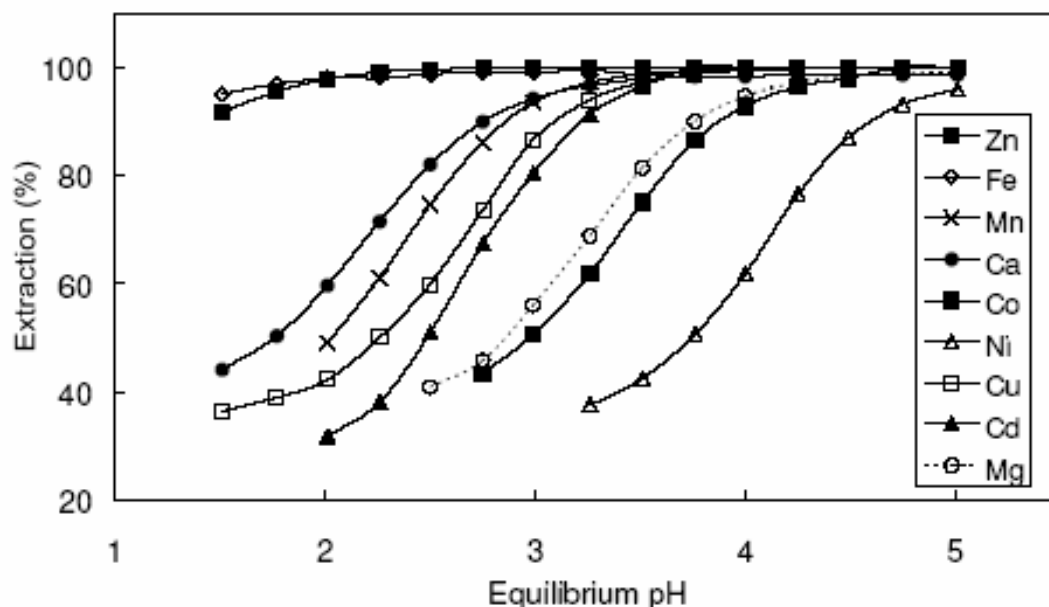

Figure 1: Effect of pH on the selectivity of extraction of base-metal cations in the Skorpion Zinc system. Conditions: 40 vol.% D2EHPA in Escaid 100, 40 °C 30g/l Zn in feed (4).

2.3 Electrowinning

The last step in the Skorpion process is the electrodeposition of zinc onto aluminium cathodes from the loaded electrolyte:



The produced spent electrolyte is sent back to the stripping stage of SX.

3.0 Plant description

A simplified Skorpion flow sheet of the process is given in Figure 2 (5). A detailed discussion of the circuit is given in (5). Following an atmospheric sulphuric acid leach; iron, aluminium and silica are precipitated from the pregnant leach solution in the neutralisation section. This neutralised and clarified pregnant liquor solution (PLS) is sent to the solvent extraction circuit (SX), (Figure 3). Extraction is performed over three stages operating at 40°C with an O:A ratio between of 1 to 1.5. Zinc is transferred to an organic phase that contains 40% v/v D2EHPA diluted in kerosene. The acidic raffinate is sent back to leaching. The first two stages of the washing circuit use demineralized water to wash out physically entrained impurity species; spent electrolyte is employed as a scrub liquor in the third wash stage to “crowd off” co-extracted impurity species from the loaded. The loaded organic phase is stripped from its zinc content by contact with spent electrolyte. Following electrowinning, the end product is SHG zinc cathodes (99.995% Zn).

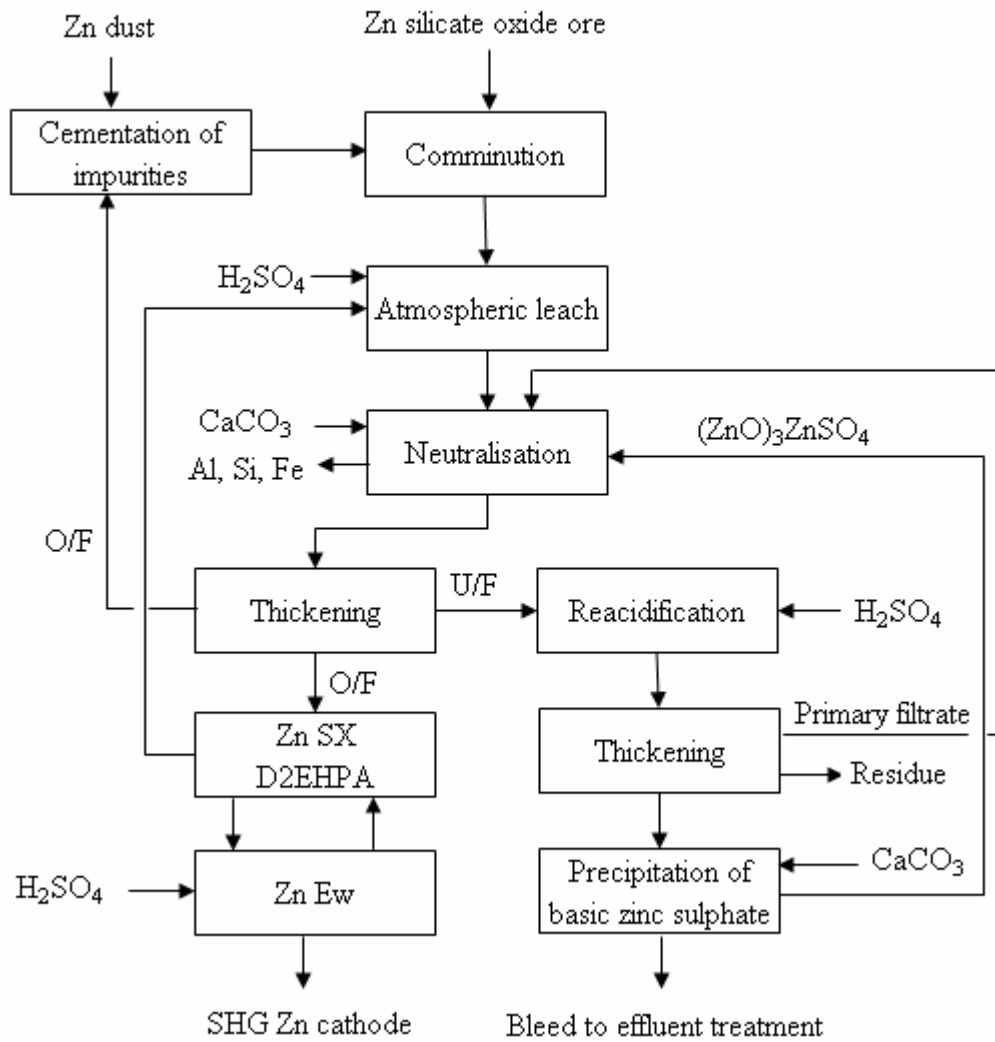

Figure 2: Simplified process flowsheet of the Skorpion Zinc refinery.

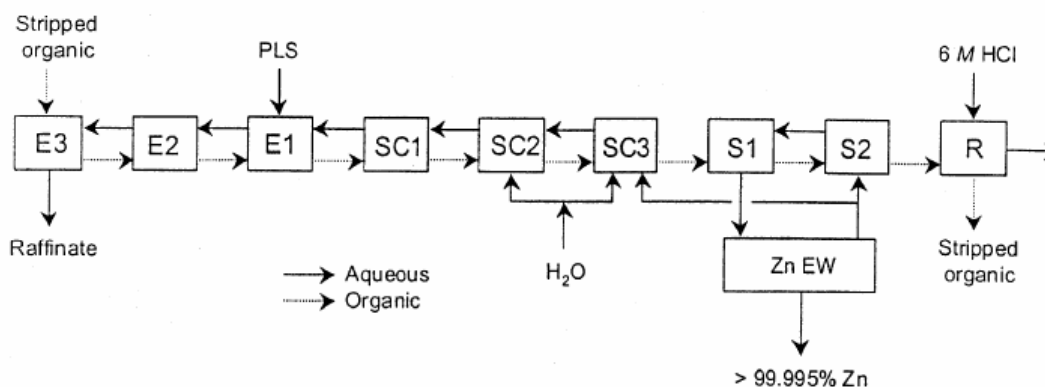

Figure 3: Schematic representation Skorpion SX circuit.

Iron and aluminium are also extracted preferentially to zinc, but cannot be easily stripped from the organic phase. For this reason, a small portion of the stripped organic is bled for regeneration. In the regeneration step, the organic is brought into contact with a strong hydrochloric solution (6 mol/l HCl) to remove all the iron. The resulting iron-chloride solution is neutralised and is returned to the leaching section.

The operating and engineering availability of the refinery was significantly increased by decoupling the electrowinning and solvent extraction sections as well as the SX and leach sections by installation of additional capacity. An additional thickener was installed to ensure flexibility and low solids transfer into SX.

4.0 Defining the problem

After more than 15 months of stable operation, a significant excursion of metal impurities namely, Cu and Ni into the electrowinning circuit forced an unscheduled shut of the refinery in August 2006. After restart of the refinery, intermittent impurity transfer across SX continued impacting on the performance of the electrowinning circuit and the output of the Refinery (Figure 4). The relative quantities of Ni, Cu, Co, and Cd transferred were consistent with the chemical composition of the PLS. A salient feature of Figure 1 is that the intermittent impurity excursions appeared as well defined spikes against an otherwise steady background levels rather than an overall increase in the impurity background suggesting a physical rather than a chemical transfer mechanism. Transfer of PLS across SX may either occur by aqueous entrainment and/or crud or another mechanism involving some degradation of the extractant or diluent. The contributions of these mechanisms are discussed below.

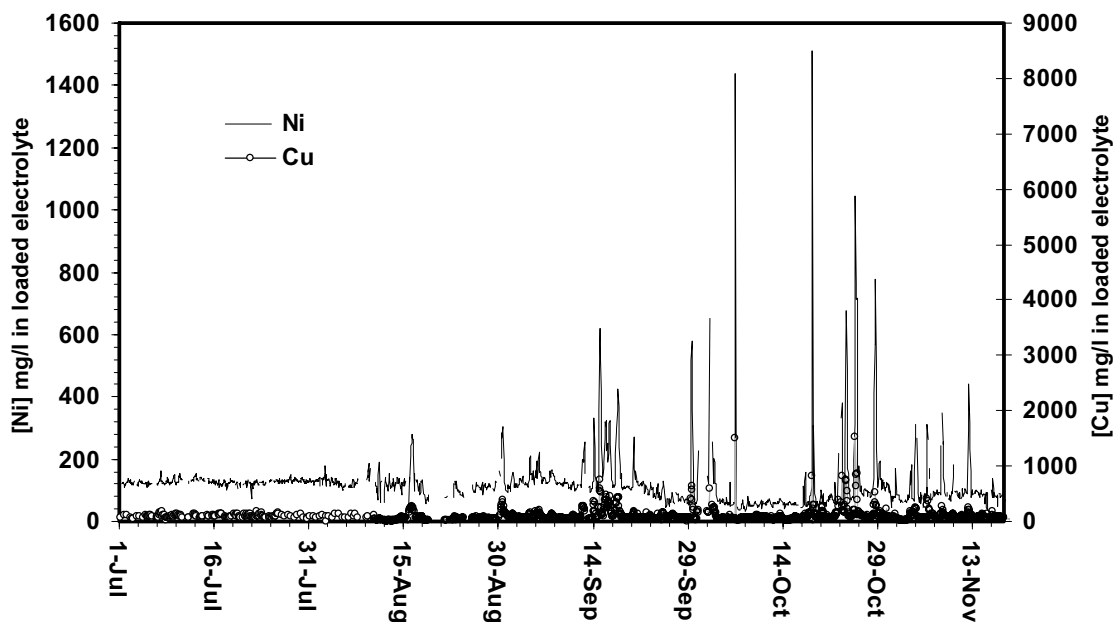

Figure 4: Evolution of impurities concentrations in loaded electrolyte (1 July -18 November 2006).

4.1 Effect of aqueous entrainment

Routine aqueous entrainment measurements averaged between 100 and 200 mg/l for the organic and aqueous extraction and washing stages. Mass balance calculations showed that these levels were too low to have caused the observed impurity levels in the loaded electrolyte.

4.2 Organic health

Standard shake-out tests on the organic phase confirmed that chemical extraction of metal impurities by the organic was within design limits, thus excluding chemical transfer as a primary transfer mechanism. Also, co-extraction was not likely to occur in the form of sporadic spikes. Sensitive Fourier Transform Infrared spectroscopy (FTIR) and Nuclear magnetic Resonance (NMR) spectroscopic analysis of the organic phase could not detect any significant degradation products.

The viscosity of the organic phase was however moderately elevated and minor changes in phase disengagement times were apparent. These alterations were suggestive of a gradual change in the physical properties of the organic phase, but were not expected to impact significantly on the hydraulic behavior. Detailed chemical analysis showed a build-up of

elements such as scandium (100 mg/l) and yttrium (100 mg/l) on the extractant. It is well known that trivalent species such as Fe^{3+} can polymerize D2EHPA and change the viscosity of the organic phase. In the Skorpion Zinc flowsheet a bleed of the organic is treated with 6 M HCl to maintain the organic-phase iron loading at 300 mg/l. Subsequent to the detection of Sc and Y, the runtime on the HCl plant was changed to ensure removal of these species from the organic phase.

4.3 Crud transfer

Crud in hydrometallurgical SX can be defined as stable, non-coalescing deposits occurring within the settler of an SX operation and originate from semi-stable aqueous-organic emulsions formed in SX settlers (7,8,9).

The formation of emulsions in the extraction stages was observed prior and during the metal impurity excursions and was accompanied by unusually high levels of mobile floating crud and accumulation of large quantities of bottom crud in the extraction settlers. Elemental analysis of the floating crud indicated the presence of significant amount of Si (9.85%), Zn (4.1%), Al (1.79%), Ni (0.03%) and Cu (0.06%). The moisture content was 37%. The crud contained therefore a significant amount of entrained PLS. The most likely cause of impurity transfer was thus the sporadic transfer of floating crud (and with it entrained PLS) from the extraction stages across the washing circuit into the stripping circuit. With intermittent crud runs as the main impurity transfer mechanism, the observed spikes in nickel and copper in the loaded electrolyte can be explained.

4.4 Causes of crud formation

The precursor to crud formation is the development of an emulsion (10). The emulsion progresses to a crud through repeated mixing, and continuous inclusion of solids and colloids. Once formed, its dispersion and separation is difficult to achieve under operating conditions. It is generally accepted that the contributing factors to crud formation are the composition and components of the pregnant liquor stream (PLS), the components or degradation products of the organic phase, and the operating equipment or operating conditions within the circuit (10). Available information on other systems indicate that the components of pregnant liquor stream with significant influence on crud formation are fine solids, silica, manganese, and foreign organic matter (10). Considering the chemical composition of the crud namely, Si, and Al it was mooted that crud formation was linked to solids carryover and the presence of colloidal silica. Solids may enter the solvent extraction (SX) circuit with the aqueous feed or precipitate during the process, while colloidal-sized, polysilicic molecules can cause serious problems in a SX system by stabilising emulsions..

The solids content entering SX is monitored by routine measurement of suspended solids (TSS). The frequency distributions of the TSS values during the impurity and after the excursions are shown in Figure 5. The average TSS value during the excursion was 52 mg/l compared to 39 mg/l after the impurity excursions. After the impurity excursions a significant fraction (34%) of the TSS measurements was smaller than 23 mg/l. This must be compared to the targeted value of <10 mg/l to minimize crud formation in SX.

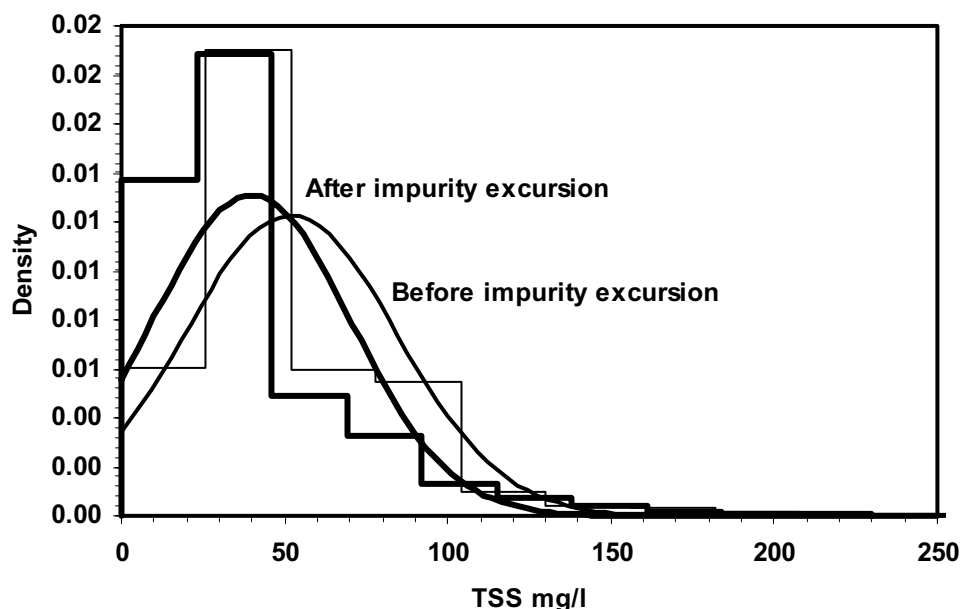

Figure 5: Frequency distributions of total suspended solids (TSS) entering SX.

An important observation during the impurity excursion was a noticeable change in the physical appearance of the crud from coarse (bottom crud) to voluminous, highly gelatinous type crud (floating crud) during the impurity excursion. In literature this type of crud has often been associated with fine clay and silica (10). The predominance of Si (27,859 mg/l) among the contaminants in the floating crud left very little doubt that it was the main contributing factor in the crud formation. Analyses of the crud suggested that it was entering the circuit in at least two different forms: soluble species (colloidal silica) and suspended solids.

Crud transfer was intrinsically linked with nickel excursions in the electrolyte. Bearing in mind that D2EHPA is not selective towards extraction of nickel under the operating conditions (Figure 1) and no evidence of organic degradation could be determined, nickel was used in the analysis below as a tracer in crud transfer.

Comparisons of the silicon concentration during and after the excursion are shown in Figure 6. There was no significant change in the mean of the concentration (60 and 63 mg/l prior and after the excursion) confirming that the form of silicon (colloidal or suspended) had a more significant impact on crud formation than the actual concentration. This was also confirmed in laboratory testwork (10): Dissolved silica had no notable effect either on the phase disengagement (PD) time or interfacial characteristics. However colloidal silica (130 mg/L) led to a slightly longer PD time and persistent cloudiness of the aqueous phase including the interfacial region. It is reasonable to suggest that this could eventually lead to emulsification, a known precursor of crud formation. These clearly demonstrated that while dissolved silica is not a major contributing factor to crud formation, colloidal silica is certainly a major contributing factor.

As indicated (section 2.1) above low pH (<2.0) in the leach section is expected to reduce the selectivity of the leaching process and increase the proportion of amorphous silicates and impurities in the PLS. Considering this, a decision was made to control the pH at 2.0 in order to maximise the stability of colloidal silica.

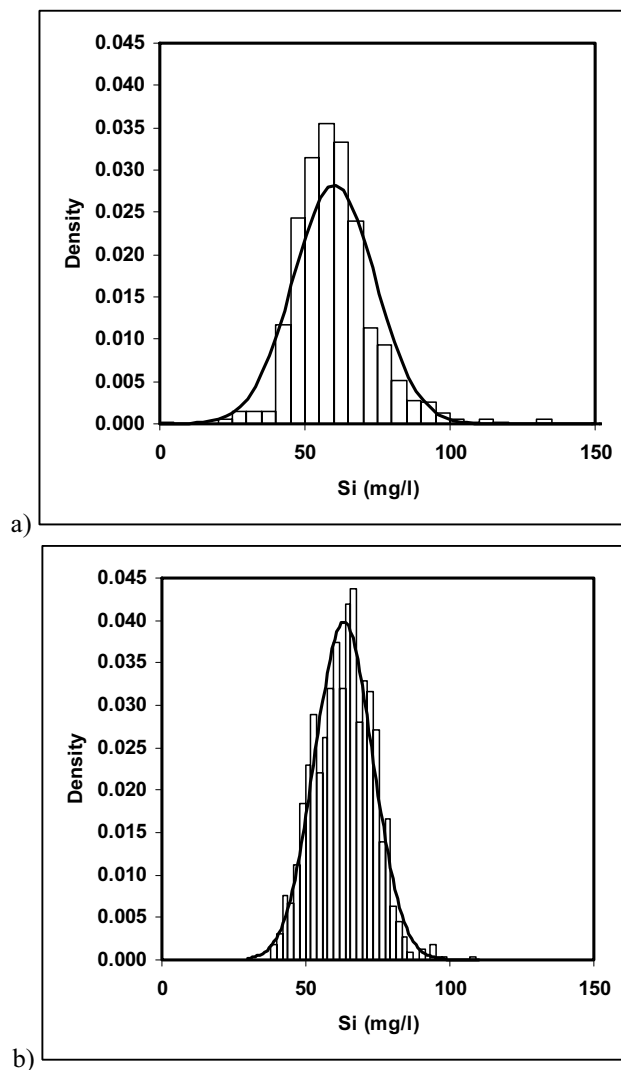

Figure 6: Frequency distributions of Si in PLS a) during impurity excursions b) after impurity excursions.

The frequency distributions of the pH values in the last leach reactor recorded for the periods during and after the impurity excursions are shown in Figure 7. The period after the excursions refers to the time when no impurity excursions were observed and the pH was controlled to 2.0. The average pH in neutralisation over the same periods remained the same at 4.2, although the variance decreased after optimisation of the pH control.

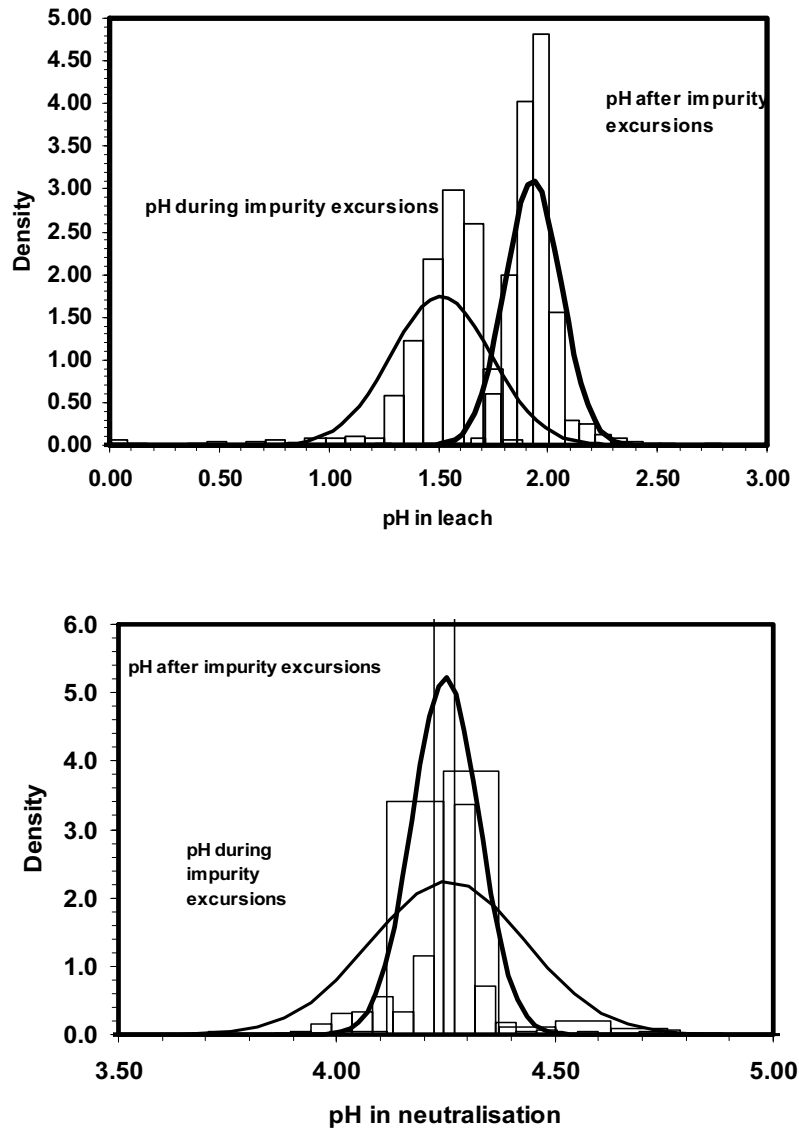

Figure 7: Frequency distributions of pH a) in last leach tank b) in neutralisation.

The significant impact of the leach pH on Ni concentrations in the electrolyte is shown in Figure 8. At the low leach pH, Ni in the electrolyte averaged 120 ppb compared to 80 ppb after the pH control was optimised at pH 2.0. Bearing in mind that the targeted value in electrowinning is 80 ppb Ni unacceptable high levels of Ni were detected during the impurity excursions. Subsequent pH optimisation resulted in far better Ni control and no impurity excursions were observed since.

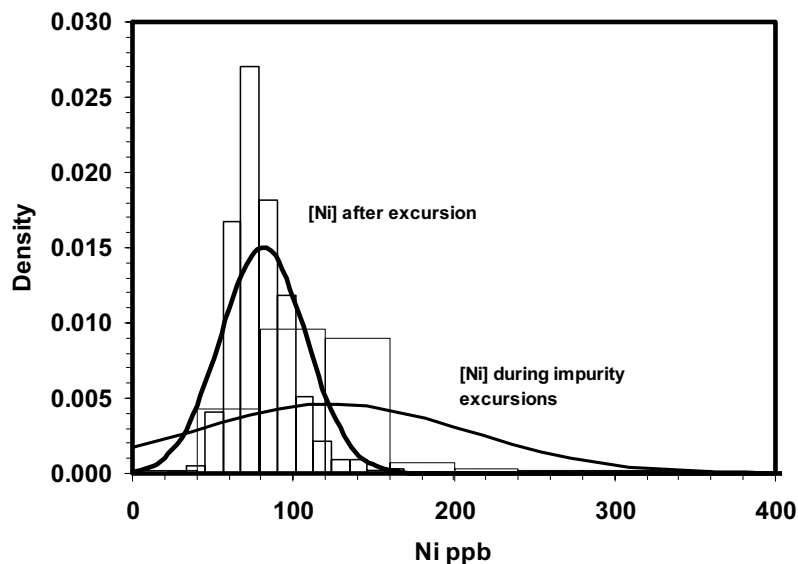

Figure 8: Frequency distributions of Ni in electrolyte.

5.0 Conclusions

The major mechanism of impurity transfer across the SX circuit has been attributed to intermittent episodes of aqueous entrainment that were associated with the build up and release of crud in the extraction stages and transfer to the electrowinning circuit. The predominance of Si among the contaminants in the floating crud left very little doubt that it was the main contributing factor in crud formation. Low pH (<2.0) in the leach section reduced the selectivity of the leaching process and increased the proportion of colloidal silica and impurities in the PLS. After adjusting and controlling the leach pH at 2.0 crud transfer episodes have reduced significantly. However, the current TSS values are still above the target of 10 mg/l. Skorpion Zinc is currently evaluating a number of solid-liquid separation technologies such as pinned bed clarification to achieve this.

6.0 Acknowledgements

The author would like to express thanks to staff at Skorpion Zinc, Técnicas Reunidas and Anglo Research and Curtin University of Technology for their assistance and helpful discussions.

6.0 References

1. Martín, D., Díaz, G., García, M. A. and Sánchez, F., “Extending zinc production possibilities through solvent extraction,” Proceedings of the International Solvent Extraction Conference, ISEC 2002, Vol. 2, Sole, K. C., Cole, P. M., Preston, J. S. and Robinson, D. J., Eds., Johannesburg: South African Institute of Mining and Metallurgy, 2002, 1045-1051.
2. García, M. A., Mejias, A., Martín, D. and Díaz, G., “Upcoming zinc mine projects: The key for success is ZINCEX solvent extraction”, Lead-Zinc 2000, Dutrizac, J. E., Gonzalez, J. A., Henke, D. M., James, S. E. and Siegmund, A. H.-J., Eds., Warrendale, PA: The Minerals, Metals & Materials Society, 2000, 751-761.
3. Díaz, G., Martín, D. and Lombera, C., “Modified Zincex Process: the clean, safe and profitable solution to the zinc secondaries treatment,” Res., Conserv. Recyc., Vol 10,1994, 43-57.
4. Sole, K. C., “Preliminary investigation of the behaviour of impurity elements and the stripping of iron(III) in the Skorpion solvent-extraction process“, Anglo American Research Laboratories Blue Cover Report, Project No. R24692/3, Report No. 8.
5. Gnoinski J., Bachmann T., Holtzhausen S., “Skorpion Zinc: Defining the cutting edge of zinc refining,” Proceedings of the International Symposium on Lead and Zinc Processing, Koto, Japan, 2005, 1315-1325.
6. Cole P.M., Sole K., “Zinc solvent extraction in the process industries“, Mineral Processing & Extractive Metall. Rev., 2003, 24: 91-137,
7. Ritcey, G. M., “Crud in Solvent Extraction Processing - A review of causes and treatment“, Hydrometallurgy, 1980, vol. 5, pp. 97 - 107.
8. Burniston, T., Greenshields, J. N. & Tetlow, P. E. 1992, “Crud control in copper SX plants“, Engineering and Mining Journal, vol. 193, no. 1 (January), pp. 32 - 35.
9. Hughes, C. A., Evans, H. A. & Warren, L. J. 1996, “Investigation of the role of silica in the formation of cruds in a hydroxyomine / sulfuric acid solvent extraction syste“, in ISEC '96, eds. Shallcross, D. C., Paimin, R. & Prvcic, L. M., Elsevier, Amsterdam, Melbourne, Australia, pp. 1277 – 1282.
10. Ibane, D.C., Helm D.J., Collard J.M., Steffens M.J.. (2006), “Assessment of crud formation in the Skoprion Solvent Extraction Circuit“, Anglo American Research Blue Cover Report, Project No. 49600, Report No. 2.