

ANGLO RESEARCH (AR) EXPERIENCES WITH INTEGRATED COMMINUTION AND FLOTATION PLANT MODELLING

Mr S Naik

(snaik@angloresearch.com)

Mr W van Drunick

(wvandrunick@angloresearch.com)

The Southern African Institute of Mining and Metallurgy

ABSTRACT

To date, Anglo Research has carried out several projects, based on the techniques developed in the AMIRA P9 (AMIRA International Limited), to develop comminution and flotation models for several Anglo Base Metals and, to a lesser degree, Anglo Platinum flotation plants.

Plant optimization is thus achieved through steady-state sampling, model-fitting and simulation using the JK SimMet and JK SimFloat software packages. The surveys can vary depending on the needs of the plant/client. The survey can therefore include as little as a single piece of equipment, an entire milling/flotation circuit, or a complete circuit from primary comminution to final flotation concentrate (i.e. the “integrated survey”).

The presence of the AR team on-site usually precipitates in face-value observations that can lead to initial improvements. This stems from the knowledge-sharing on best practice that exists in parallel with the surveys. Numerous (reasonable) changes can then be simulated, thus indicating the optimization step most likely to result in the best efficiency improvements. The simulations can include changes in the flowsheet, ore characteristics, mill loads, grinding media size, change in grind, flotation residence time, air hold-up and several more. Plant surveys can result in process changes that provide the plant with either: higher plant tonnage, improved plant grind, additional flotation recovery and/or improved product grade. The additional benefit of performing an integrated plant survey is that the effects of an optimization change in the comminution circuit can be simulated using the flotation model.

This paper describes a number of case studies where individual and integrated plant surveys were conducted by AR for Anglo Base Metals.

1. Introduction

Anglo Research (AR) on behalf of Anglo American plc (a sponsor of the AMIRA P9 project) has become involved in the AMIRA P9 comminution and flotation modelling projects over the last few years. During this period, AR has carried out detailed sampling and measurement campaigns in the both comminution and flotation concentrators of various Anglo Base Metal Operations on an individual basis and also as integrated surveys as described in Table 1.

Table 1: List of AR flotation modelling exercises

Date	Operation	Circuits	:	Survey Type
2002	Lisheen	Pb, Zn	:	Flotation
2003	Hudson Bay	Cu, Zn	:	Flotation
2004	El Soldado	Cu	:	Flotation
2004	Las Tortolas	Cu	:	Flotation
2004	Mantos Blancos	Cu	:	Flotation
2004	Los Bronces	Cu	:	Comminution
2005	Lisheen	Pb, Zn	:	Integrated
2006	Catalao	Nb	:	Integrated
2006	Black Mountain	Cu, Pb, Zn	:	Flotation
2007	Copebras	P ₂ O ₅	:	Integrated

The focus of this paper is not to explore in detail any particular aspect of this process. This paper aims to describe (briefly) a number of activities that comprise a typical modelling campaign and to provide examples and experiences of how processing plants have benefited from this integrated surveying approach.

The on-site work described in this paper was carried out by AR metallurgists with assistance from the respective site personnel. JKTech personnel were present during the first campaigns for both the Comminution and Flotation, which also functioned as a training exercise. As a result, AR now carries out typical P9 exercises, although JKTech has sometimes remained involved as a consultant. AR has gained experiences during the course of this project which have led to these exercises becoming increasingly efficient.

2. Description of Modelling Process

Typically, prior to the actual sampling campaign, a first trip to the site is made to inform all concerned about the aims of the exercise as well as to meet potential assistants, and to gather information about the circuit. A generic planning document is issued to the site for familiarisation with the survey process, equipment, analyses required, etc. Thereafter, a further four to six weeks is normally required for the plant to prepare for the exercise. This usually involves creating access for sampling and measurements with the mills, cyclones and the flotation cells. A typical integrated sampling exercise takes on average one week, during which the following activities are carried out:

- Detailed survey of every available stream in the comminution circuit
- Additional sampling for BWI, RWI and JK Drop Weight tests
- Measurement of mill dimensions, liners specs, etc.
- Scada data to assist in mass balancing, power modelling, steady state and process control analyses, etc.
- Detailed survey of every stream in the flotation circuit (for model building)
- Laboratory batch flotation tests ‘Hot Floats’ of critical streams (to collect additional kinetic data)
- Cell hydrodynamic measurements (to characterise the cell behaviour);
 - Superficial gas velocity (Jg)
 - Air hold-up
 - Bubble size
- Residence time studies (to confirm mass balance and to determine cell mixing characteristics)
- Alternate circuit survey (for additional model validation, if possible)

For the sampling exercise itself, AR has found it essential to do as much work as possible on a single day for each of the comminution and flotation circuits. To date, experience has shown that no plant operation is so stable as to allow consistent detailed sampling from day to day. Typically, few plants can be relied upon to have less than a five per cent relative change in head grade from one day to the next, and whilst this may have only a limited effect on the overall performance of the plant, the change in assays from samples of individual cells can be markedly different. Hence AR involves as many people as possible in the survey. Certain measurements such, as bubble size and superficial gas velocity, for which no slurry samples are taken, are less sensitive to ore changes and so these measurements can be made on other days although ideally they are best taken on the same day. The slurry samples, which represent a snap-shot of the process, are used to model the equipment and the process.

The aim of this exercise is to generate an accurate detailed mass balance of the plant to fit parameters for modelling. This is to some extent different from the aim of obtaining an overview of average plant performance. Hence, often contrary to conventional wisdom, experience to date has shown that single cut ‘snap-shot’ sampling can be as good as, if not better than, multi-composite sampling.

In addition, mine management must be informed that the current models are ore specific and so, in order for the model to be of maximum benefit, the mine must attempt where possible to run on typical material. If necessary, it is advised that sampling be postponed rather than develop a model on non-typical ore. Laboratory batch flotation tests are carried out to collect additional kinetic data for modelling and in addition to confirm certain parameters such as residence times and additional cleaning steps. Mill crash-stops and grind-outs are conducted to determine accurate mill dimensions and load/ball volumes.

In total, approximately 300-350 samples are typically collected during the week-long test program. This requires careful planning in the sample preparation laboratory. Assay and screening results are generally received approximately five to seven weeks after the end of a campaign. Mass balancing, modelling and analysis typically take a further two to three months.

3. Modelling Approach

The comminution section is modelled in JK SimMet via a range of available models. The choice of model depends on the nature of the machine and the quality of the data. For ball mills, the perfectly mixed ball mill model is typically used. Seven different models are available for each of the screen and cyclone modules. SAG/AG mills have four models available, and the “variable rates” model is typically used. The general spectrum of comminution-type equipment can be modelled in the flowsheet, from cone and jaw crushers to HPGR’s and the associated classification devices.

The general principle of the flotation modelling approach is the decoupled model of flotation as shown in Equation 1 below. Cell parameters such as bubble surface area flux, residence time, water recovery and the overall recovery can be measured and calculated for each cell from the mass balance information collected during sampling. To a lesser extent entrainment and froth recovery can either be predicted or measured. P_i – the fundamental flotation response – is then fitted as a distribution. Many data points throughout the circuit, and the accompanying on-site laboratory batch flotation tests, are used to ensure a high degree of confidence in the fit.

The AMIRA P9 recovery model for flotation for species i in a perfectly mixed cell:

$$R_i = \frac{P_i \cdot S_b \cdot \tau \cdot R_{fi} \cdot (1 - R_w) + ENT_i \cdot R_w}{(1 + P_i \cdot S_b \cdot \tau \cdot R_{fi}) \cdot (1 - R_w) + ENT_i \cdot R_w}$$

(Eqn. 1)

where:

- R_i = recovery
- P_i = floatability
- S_b = bubble surface area flux
- τ = residence time
- $R_{f,i}$ = froth recovery
- R_w = water recovery
- ENT_i = entrainment parameter

True Flotation

Flotation via
Entrainment

Having characterised the ore, the model can then be used to simulate circuit changes and to assess various ‘what-if’ scenarios. However, many of the measurements and intermediate results are often as useful as the final simulator which results from this process. These are discussed in turn.

4. Modelling Results

The aims of a plant model can be either specific or general. For example, one may require a model to determine the optimal circuit configuration to produce a target grind, grade or recovery. A general aim would be to analyse the overall performance of the plant in terms of the ore as well as the performance of the individual mills/cells and to investigate possible

areas of improvement. In this section, for each of the activities typically carried out on the plant during a modelling exercise, some examples of results are presented and discussed.

4.1 Mill Performance and Efficiency Parameters

A number of measurements and efficiency parameters are measured for every comminution campaign. Throughput and power draw are insufficient in determining the efficiency of a mill with respect to its design parameters. The overall performance of a mill is collectively based on a number of factors, that include: liner design, discharge grate design, percentage of open area at the mill discharge, respective grinding media (type, size and loading), product PSD, etc.

Figure 1 below shows a typical mill breakage and discharge rate curve with respect to size. The discharge of slurry is most efficient below approximately 400um, after which the slurry discharges more slowly. This is particularly useful for altering the mill discharge design for improved throughput. In addition to this, the breakage rate curve for a SAG mill displays a “dip” between 20 and 70mm. This indicates the critical size material size range, which is critical to correctly sizing a discharge trommel and also setting the recycle crusher gap, for instance.

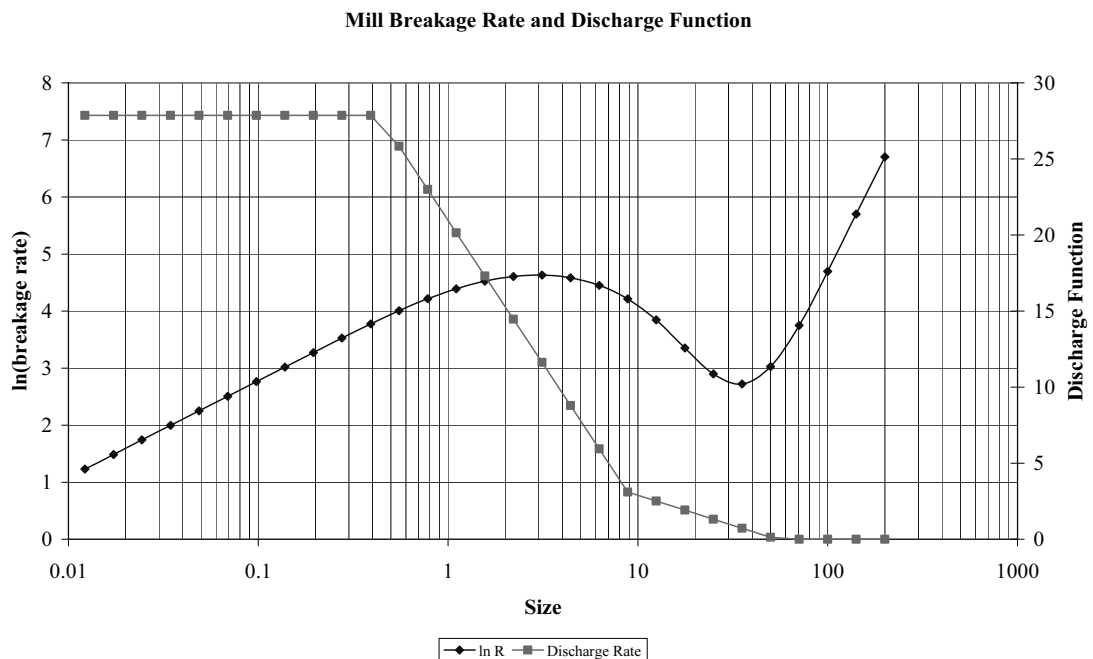

Figure 1: SAG mill breakage and discharge functions

4.2 Flotation Performance Parameters: Gas Dispersion Measurements

4.2.1 Bubble Size

The earlier testwork made use of the McGill Bubble Sizer (see Hernandez-Aguilar *et al*, 2002 for more details) while more recently AR has made use of the Anglo Platinum Bubble Sizer presented in Figure 2. Although there are published empirical correlations to predict the bubble surface area flux (eg Gorain, Franzidis and Manlapig, 1999) and hence, indirectly, bubble size in mechanical cells, prediction of bubble size in columns has been less well quantified and so a measurement is essential.



Figure 2: Anglo Platinum Bubble Sizer

Figure 3 presents typical bubble sizes of between 1.4 - 1.8 mm (d_{32}) in the conventional rougher cells. This is in agreement with literature sources (Deglon, Egya-Mensah and Franzidis, 2000; Power, Franzidis and Manlapig, 2000) which indicates that bubble sizes of less than 2mm are suitable for flotation. Interestingly, in the secondary circuit, the bubble size decreases down the rougher bank and this may be the result of the frother addition down the bank. The d_{32} of the primary rougher 9 cell was measured to be high at 2.5mm indicating frother requirement.

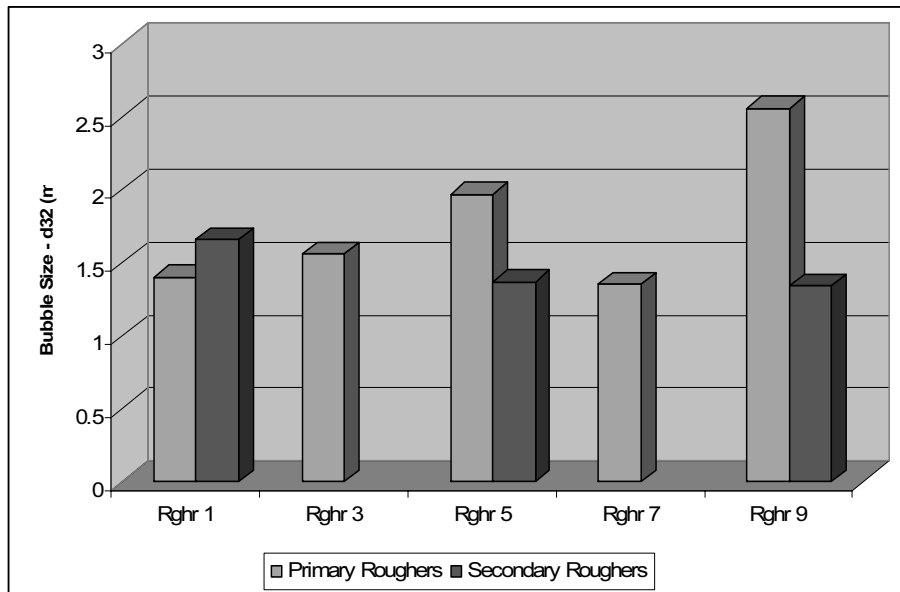

Figure 3: Bubble size distribution down the rougher banks

Bubble size measurements improve the confidence in the simulations because of the more accurate determination of the bubble surface area flux (S_b). Bubble size results also demonstrate whether the cells and the reagent regimes are creating typical bubble sizes needed for flotation. To date, this has been the case in all the cells measured. The bubble size analyser may provide a tool to evaluate different reagent and/or cell conditions. However this has not been done in any AR studies as yet.

4.2.2 Superficial gas velocity (J_g)

The P9 recovery equation contains a parameter S_b , the bubble surface area flux. This requires knowledge of the superficial gas velocity J_g and the Sauter mean bubble size (d_{32}). Measuring J_g in a cell also allows the operation of the cell to be compared to that of other cells, in the same plant and in other plants (eg Power *et al*, 2000) and it allows the use of the cell for other purposes to be predicted in simulations. The Anglo Platinum Bubble Sizer is also used to measure this parameter.

Although modern cells are often fitted with air flow metres, the J_g probe remains useful for calibrating the accuracy of the measurement. Sometimes several cells use a common air source and the J_g probe can identify bias in the amount of air fed to each cell. In one case, the J_g measurement quickly revealed that the air flow to a certain cell was constrained. Additionally, for self aerated cells (e.g. Wemco), the J_g probe is essential to measure and/or compare the air flow rates.

In Figure 4, a comparison of the J_g measurements in a plant shows that there is room for improvement in the rougher and cleaner scavenger cells by adding more air. Typically Froth recovery permitting, the cells may perform better at deeper froth depths and higher air flows.

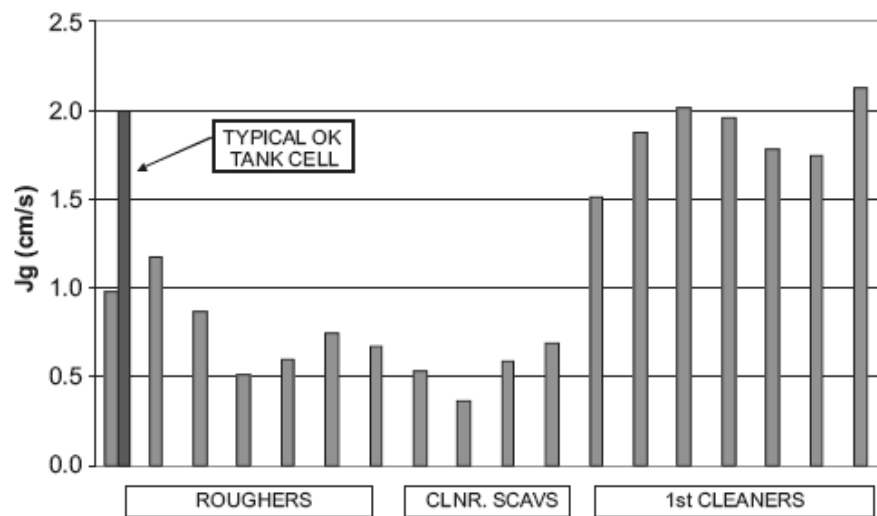

Figure 4: Comparison of J_g values (cm/s) for various Outokumpu tank cells in a circuit

4.2.3 Air hold up (AHU)

The principle of the air hold up measurement device (shown in Figure 5) is that a sealed volume of aerated pulp is captured from a cell, and when released into a measuring cylinder, the difference in volume to that of the sampler corresponds to the air fraction.



Figure 5: Air Hold Up (AHU) device

This measurement is useful in residence time determination, providing a correction for the volume of air within a cell. This improves the accuracy of the models. The air hold-up sample serves an additional purpose as a sample of the pulp for froth recovery calculations.

As a diagnostic tool, air hold-up has had only limited application. Typically, on the plants visited to date, air hold-up and J_g have been approximately proportionally related: cells with

low air flows have also had low air hold ups. High air hold-up measurements (~30 per cent) can be an indication of high pulp viscosities. However, this has not been encountered to date.

4.3 Residence Time Studies

Solution tracer studies are conducted as part of the plant modelling exercises to determine the liquid residence time in various stages of the circuit. While these are not the highest priority in the exercise they are useful for comparing with the mass balance, and particularly in determining the water balance which is typically less accurate than either the solids or mineral balances. Both LiCl and NaCl have been used as tracers. The calculation of the required concentration is based on the minimum needed to make a distinguishable peak even in the worst case scenario (when the salt disperses perfectly).

4.4 Froth Recovery determination

Froth recovery reflects the loss of recovery of attached particles in the froth phase. Froth recovery (Rf) of 100 per cent (as assumed in the shallow froths in laboratory batch flotation tests) implies no loss of recovery due to the froth phase. A number of techniques are available to measure froth recovery. In the AR exercises to date, the mass balance approach suggested by Alexander, Franzidis and Manlapig (2003) has been adopted. Simultaneous mass balances of attached and entrained material, using feed, pulp and tails samples from a flotation cell, combined with a sample from the top of the froth, allow the froth recovery of attached minerals to be calculated. To date however, this approach has yielded little success, perhaps due to the need for extremely accurate sampling. Triplicate samples may be needed to identify the subtle changes in grade, which is often not practical for a complete circuit of many cells. At best, the approach may work for certain cells which are then used as indicators for the remaining cells in the circuit. The implication of this difficulty to measure froth recovery consistently is that Rf becomes another fitted variable in the floatability determination fit. This makes it all the more important to collect sufficient data to ensure an accurate mathematical fit.

4.5 Detailed Survey Sampling

Microsoft Excel Solver techniques are used to fit the mass balance flows around the circuit from the assay data of the various elements. A common finding in all of these plant modelling exercises is that a detailed cell by cell mass balance is in itself a critical diagnostic tool. For example, Figure 6 shows the mass distribution across the rougher bank while Figure 7 presents the distribution of copper down the bank while very little lead is collected.

Additional collector (both SIBX and Sascol 61) has been added at the mid-point of the rougher bank. Note how the mass pull to the concentrate increases after the addition of the reagents, indicating that there may be merit in stage addition of the reagents for this orebody in order to improve the mass pull to the concentrate.

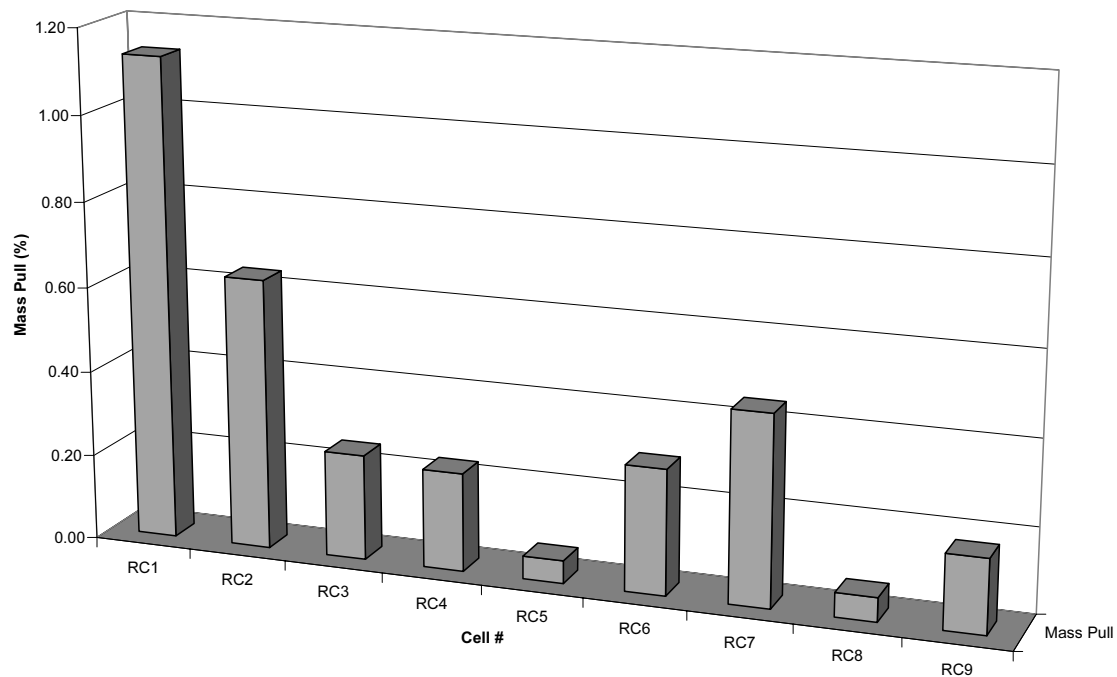

Figure 6: Mass recoveries down the primary rougher bank

Figure 8 presents the overall recoveries (by size) for one of the Base Metal concentrator plants. In this example the use of assay-by-size mass balances identifies the critical fractions which account for the losses. A majority of the losses, (approximately 65%) in the primary rougher tail is in the +53 μ m fraction. In addition, most of the valuable material lost in the cleaner 7 tails is in the -10 μ m fraction (approximately 86%).

The use of mineralogy further identifies the potential reasons for the losses. Examination of the cleaner tails stream showed that over 40% of the valuable material in this fraction is liberated while the remainder is either locked to or attached to the gangue minerals.

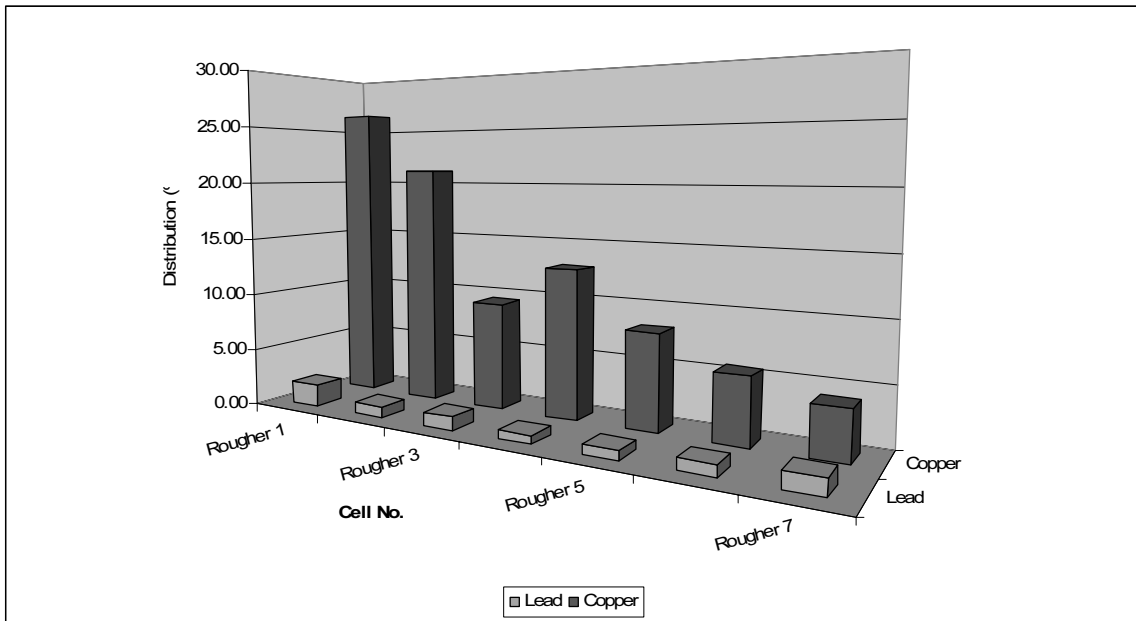

Figure 7: Base Metal distribution down the rougher bank

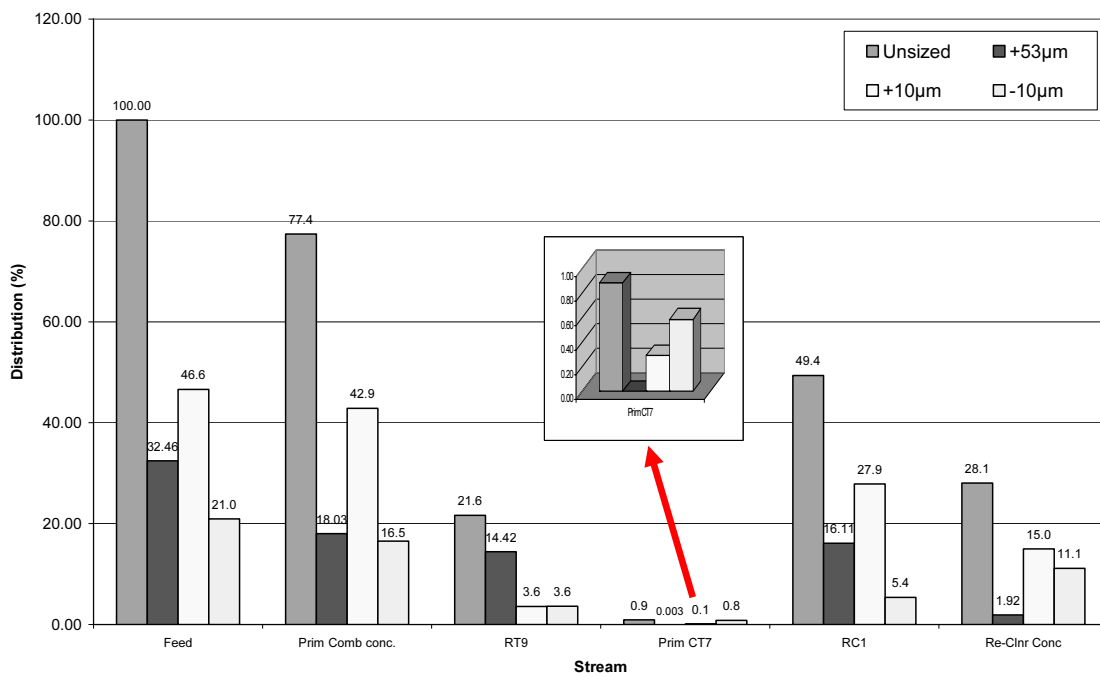

Figure 8: Distribution by size class

4.6 Laboratory Batch Flotation Tests

Laboratory batch flotation tests are carried out on critical samples, typically feed, concentrates and tails, from each stage of the process using exact duplicates of the samples sent for screening, chemical and mineralogical analysis. The kinetic recoveries measured in these tests provide further information which is used to increase confidence in the fit of the ore's floatability distribution. Typically 10 -15 laboratory flotation tests are carried out per circuit, and these generate an additional 112 to 160 data points which can be used in the model fitting. The results of the laboratory batch flotation tests on the rougher tails stream are an indication of the content of 'non-floating' material in the ore. Valuables which are not recovered in these tests at the 10 per cent froth recovery conditions of the laboratory batch cell are considered non-floating. This is a useful number to evaluate the actual plant recovery, and to quantify any potential scope for improvement in the circuit. Figure 9 presents the possible recoveries from the feed and concentrate samples as well as the potential to recover some of the valuables from the exit streams.

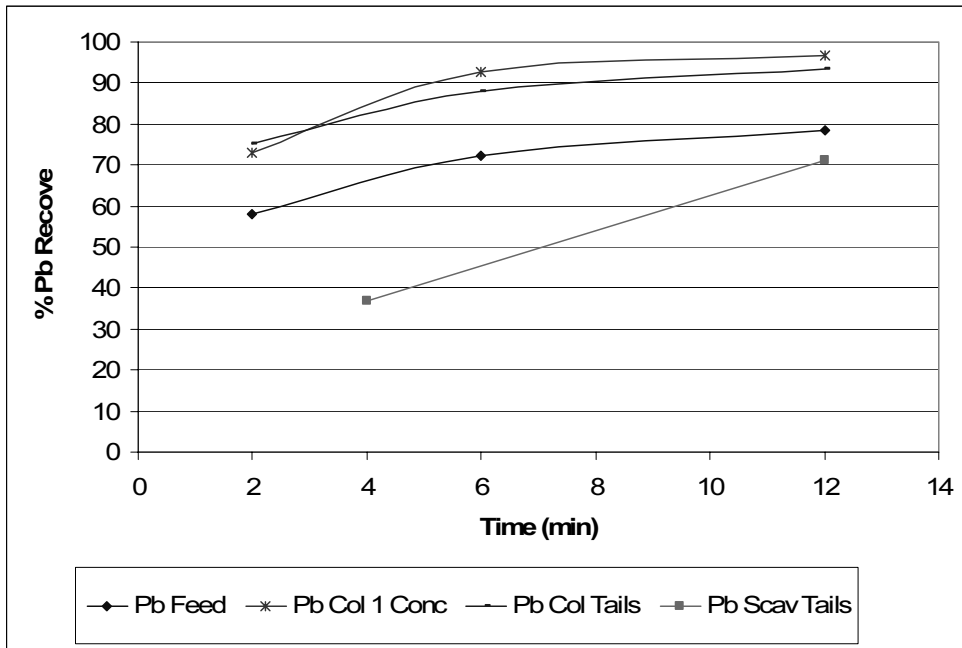

Figure 9: Pb Recoveries in a Batch Flotation Cell

The laboratory tests are also critical in evaluating 'nodes' at which there is a change in floatability, for example at points in the circuit where there is reagent addition or a regrind mill. In general, AR work to date suggests that reagent addition within circuits has only limited effect on floatability. The effect of regrinding is demonstrated in Figure 10 which shows kinetic recovery curves before and after a regrind mill. The finer grind leads to an improvement in both the kinetics and recovery.

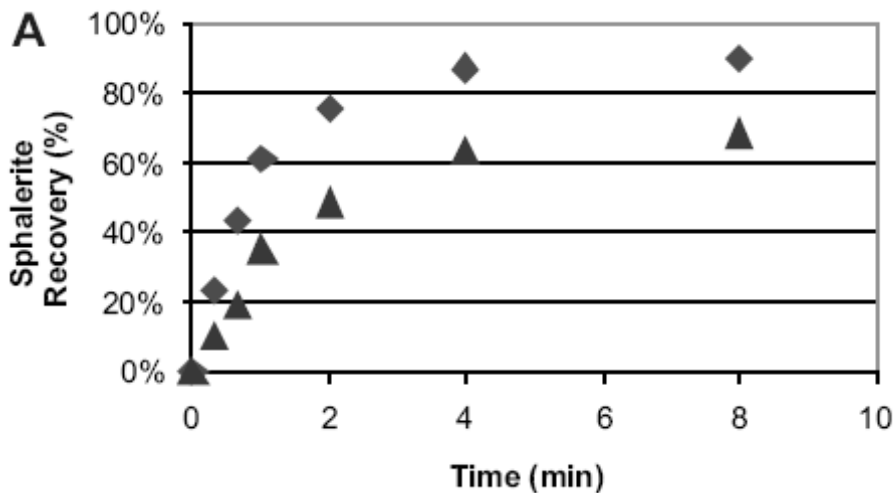

Figure 10: Sphalerite recovery in the laboratory batch test before and after re-grinding

5. Model fitting

Once the mass balance of the comminution circuit has been completed, it is then possible to model-fit the circuit. This is done by fitting parameters to the equipment models, usually starting with an intelligent estimation of the parameter. The feed data to the equipment is then entered into the model, and a good fit is obtained when the model accurately predicts the sampled product of the equipment. Figure 11 below shows the typical range of parameters fitted to a hydrocyclone and a SAG mill.

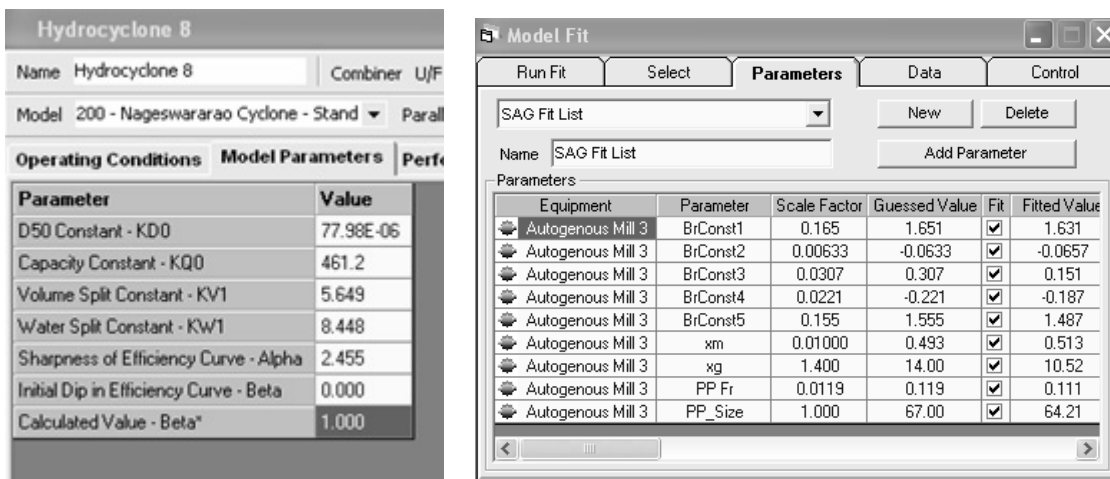

Figure 11: Typical model parameters for a hydrocyclone cluster and SAG mill

With respect to the flotation results, once all the results of the measurements and the mass balance and laboratory flotation test data have been collected, the next stage in the process is to fit the floatability distribution of the feed ore. An example of a floatability distribution for galena and sphalerite in a lead circuit is shown in Table 2. With a feed of this floatability distribution, it will not be possible to recover the slow floating galena without also recovering

approximately nine per cent of the sphalerite. This is an example of how this approach helps to quantify and hence identify the causes of problems within a circuit.

Table 2: Floatability distribution of sphalerite and galena in a lead circuit

	Galena		Sphalerite	
	Pi	Xi	Pi	Xi
Fast	0.008675	0.748	0.00786	0.01
Medium			0.00143	0.085
Slow	0.0005	0.078		
Non	0	0.174	0	0.905
Total mineral	-	1	-	1

6. Circuit Simulations

The final stage in the process is the development of a circuit simulator using all of the information described in this paper. Once the models have been fitted, they are then ready to run simulations on a host of changes in either the process flowsheet or operating conditions or equipment dimensions. It is also possible to conduct simulations using combinations of all of these changes (within reasonable limits). Figure 12 below shows a typical SABC circuit simulation flowsheet in JK SimMet. This particular circuit simulator was used to determine (among other things) the effect of total plant throughput on the final grind.

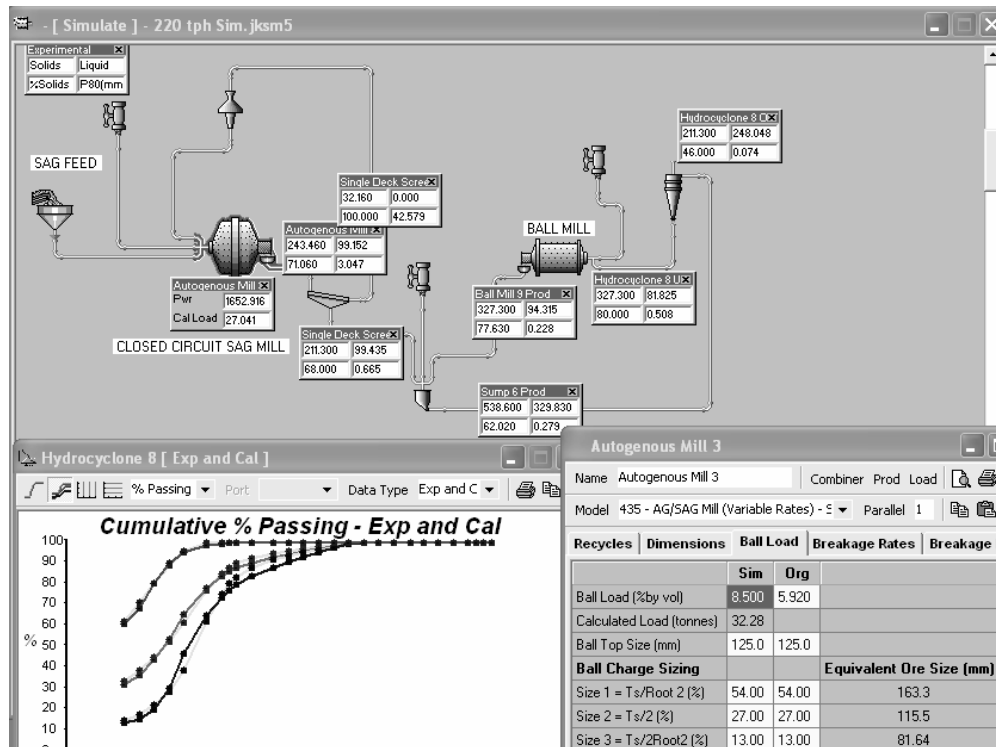

Figure 12: Typical SABC circuit simulation flowsheet

Figure 13 below shows the effect of increased throughput on the cyclone overflow PSD.

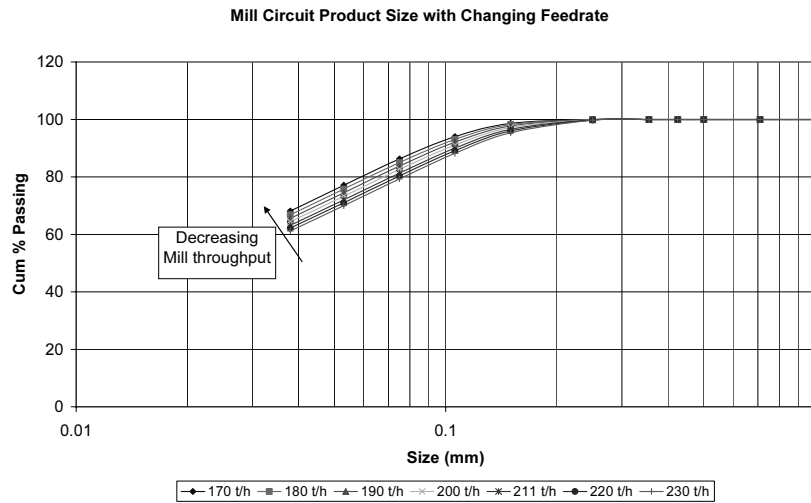

Figure 13: Effect of throughput on final circuit grind

AR uses JK SimFloat (Harris *et al*, 2002) to run the flotation simulations. A JK SimFloat screen is shown in Figure 14.

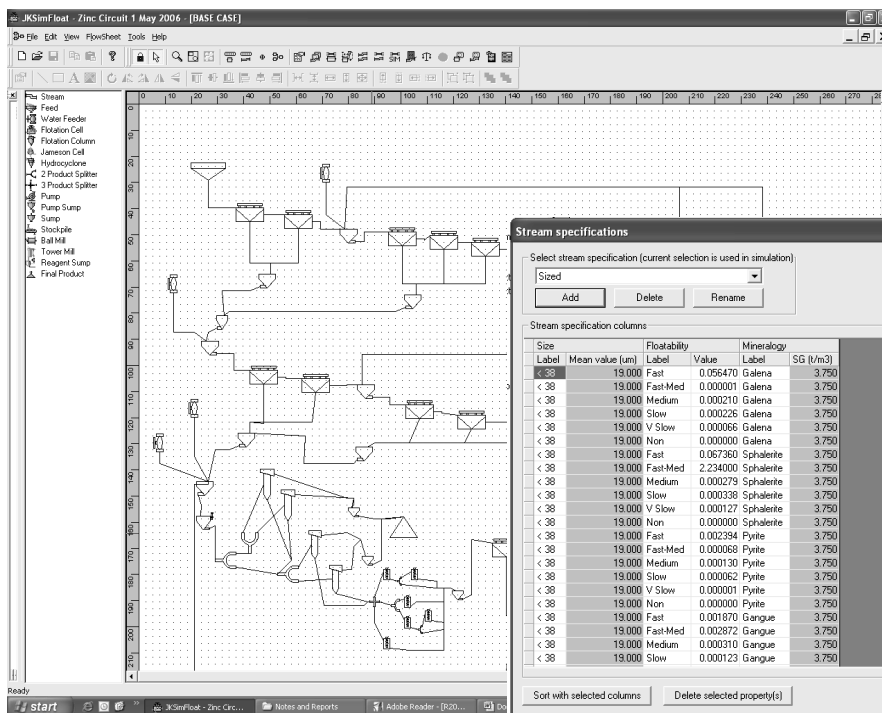

Figure 14: Typical JK SimFloat screen showing inputs and the flowsheet in the background

The first step once the simulator is working is to run a changed circuit in order to validate the plant model. At each site, a request is made to change the circuit and to survey this changed circuit. The plant must be prepared to operate this circuit until it stabilises. In general, AR has obtained good model validation when the changed circuit runs on similar ore to that of the original survey. However, there have been occasions where the ore has changed and the prediction does not match the actual changed circuit performance. This experience

emphasises the need to do as much sampling as possible on a single day. Note that the relative changes in performance predicted by the simulator are believed to be far more robust and to apply even when the feed ore changes. However when comparing to the results of the original detailed survey, it is essential to have similar ore to evaluate the quantitative effect of the circuit change on plant performance.

A typical basic simulation is to vary the residence time. Although additional cells are often not an option on the plant, this gives an indication of any bottlenecks in the circuit. Other simulations which are typically tested, and are more likely to be possible to implement in reality, are:

- changed air flows,
- water addition,
- open circuit/closed circuit cleaning and the tails return point,
- rougher-scavenger split in banks, and
- multiple stages of cleaning.

An example of an AR simulation which was implemented in practice is shown in Figure 15. The simulation showed that returning the first cleaner tails to the fourth rougher cell feed would give the same recovery and grade as that achieved when it is returned to the feed of the circuit. This change would however greatly benefit the plant in terms of the improved stability of the first two rougher cells which are responsible for the majority of the circuit recovery. Hence the plant has implemented and maintained this change. Unfortunately, the benefits achieved with increased stability are difficult to quantify exactly.

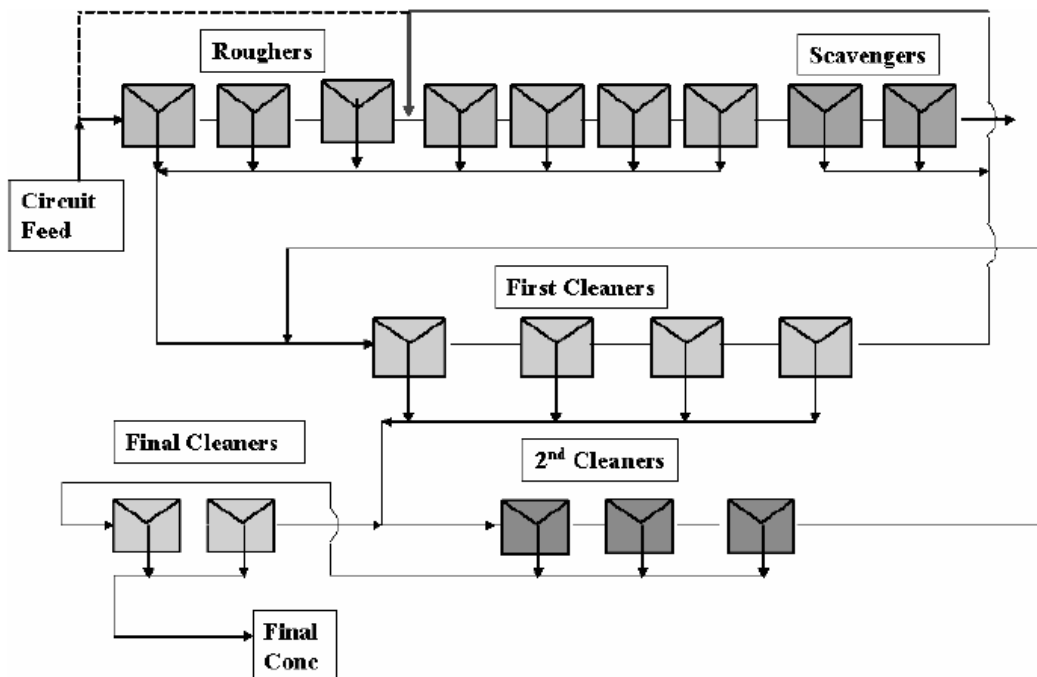

Figure 15: Circuit change as a result of simulation

The second example illustrates how the simulator can be used not only to identify the need of additional cleaning capacity but also where to route the concentrate stream. The need for additional retention time was identified in the first cleaner stage, (in a three stage cleaning

circuit). However, with the aid of the simulator it was identified that in order to maintain the final concentrate grade, the concentrate from the additional cell should be sent back to the feed to the first cleaners rather than the feed to the second cleaner stage. (i.e. the cell is acting as a cleaner scavenger). The circuit configurations are illustrated in Figure 16.

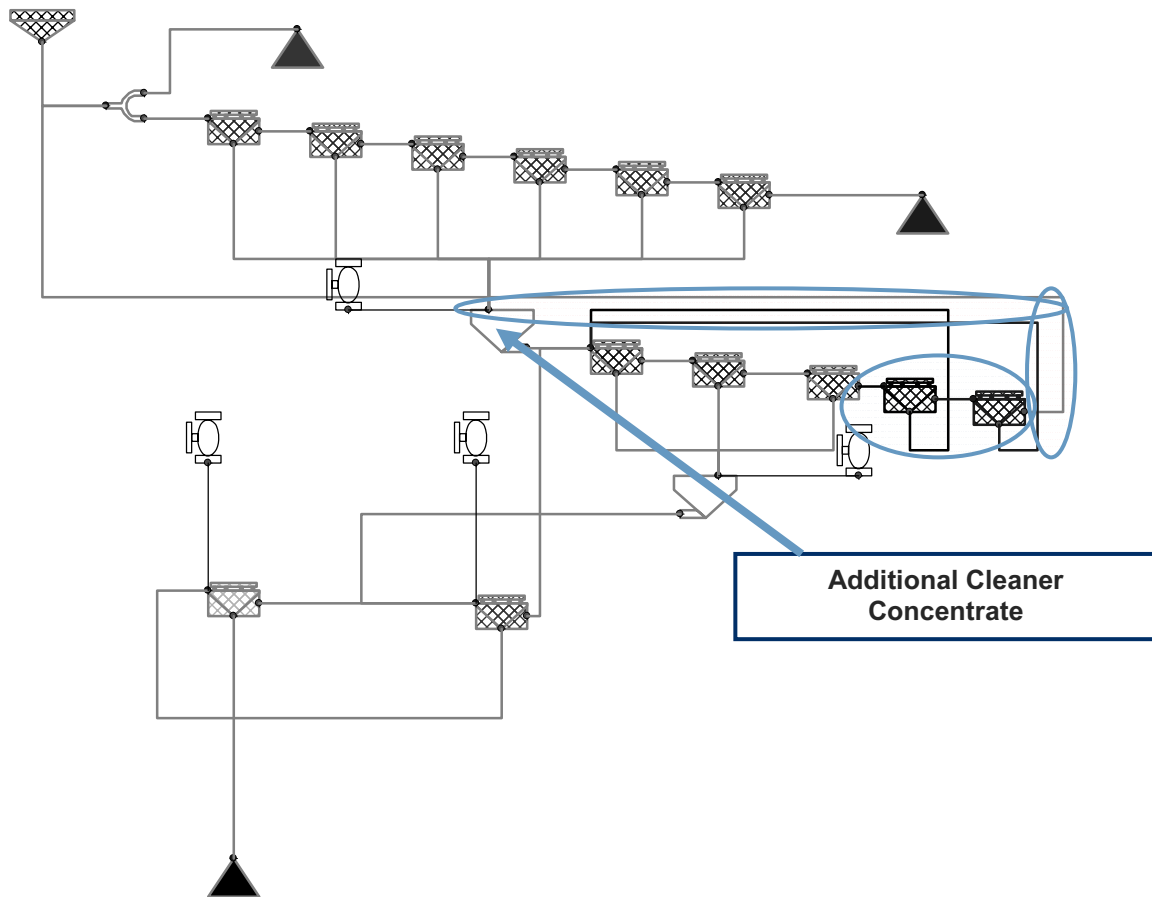

Figure 16: Addition of Additional Cleaning Capacity

7. Developments

Although the JK SimMet and JK SimFloat packages are able to produce reliable simulations, the development of the models is still on-going. Much of the research and development of the models is done through the sponsor-funded research done through Amira P9.

The original JK mill and cyclone models have been radically improved in recent decades, and the current version of JK SimMet includes the best of these models. However, due to the different aspect ratio's of mills and the very large diameter mills that are currently being built, the models are constantly being upgraded. Powell is currently developing the UCM (Unified Comminution Model) which aims to account for a broader range of mill dimensions, including the effects of size on the breakage rate of an ore component and also the effect of segregation in low aspect ratio (poorly-mixed) mills.

The majority of the data presented in this paper is from exercises in which the floatability component approach was used to represent different floatability classes of each mineral. The most recent AR exercises have included assay by size analysis to improve the accuracy of the models. This is particularly necessary in circuits including a regrind milling stage, and possibly also column cells which are believed to be more sensitive to particle size. In these cases, the potential uses of the mass balance results will have an additional level of complexity. The further inclusion of mineralogical analysis is clearly an additional level of complexity, which has considerably aided in the understanding of the flotation kinetics. However, it is advised that modelling should always proceed sequentially in order of increasing complexity (and cost) of analysis. Firstly, this will allow intermediate reporting of results to the plant, and secondly will provide a check that only appropriate samples are sent for analysis, as can be the case in the event of changing plant head grades for example.

8. Integrated Surveys

The following is a description of a recent example where the benefit of integrated surveys was evident: On a particular Lead-Zinc mine, the flotation survey results indicated that the placement of the re-grind mill was inappropriate. The re-grind mill was treating the column tails which then fed a bank of scavenger cells. The concentrate from these cells was then sent to the column feed. Mineralogical examination of the column feed showed that a majority of the minerals were in binary phases with pyrite and hence it would be beneficial to re-grind the column feed rather than the column tails to liberate the minerals in order to achieve higher concentrate grades. The plant was reluctant as they felt that the efficiency of the re-grind mill would be hampered by the additional mass flow through the mill. However, since the re-grind mill was also surveyed as part of the integrated comminution-flotation survey, the new throughputs were simulated and results showed that with changes to the steel media load and ball size, there was sufficient capacity to treat the column feed and obtain the desired grind. The changes were implemented by the plant with success.

In addition to this example, there have also been cases where the flotation survey has recognised certain size classes that do not float well (either too coarse or too fine). The milling optimisation was therefore aimed at reducing the amount of material outside of the desired size range, by creating a steeper product PSD.

Throughput is often the desired target of many grinding plants, but the effect of reduced flotation residence time is difficult to estimate without a flotation model. The integration of the flotation survey thus makes it possible to determine the effects of tonnage and grind on recovery and grade. In addition, the flotation simulator is also able to simulate which changes of the cell conditions would be able to cater with the anticipated changes.

9. Conclusions

This paper has given an overview of some the work done and the results obtained in the AR comminution and flotation modelling project over the last few years. The potential benefit of each of the phases of a typical plant modelling campaign has been demonstrated.

Comminution circuits are modelled to the extent that the effects of circuit changes can be confidently anticipated (whether the output is an accurate prediction or a relative change in the process). The changes that can be simulated include: flowsheet configuration, flowrates, operating conditions, equipment parameters, ore competency and many others.

The flotation cell characterisation equipment is useful in determining the actual performance of the cells, in terms of air flow and bubble size. Typically, these results are compared to industry averages and advice can be given in cases where non-typical performance is measured.

In AR's experience, the detailed cell by cell mass balance and the laboratory batch flotation tests are often the most useful stage of the modelling exercise. Not only is it the most easily understood and trusted by plant management, but it can be produced within a few weeks of receiving the data and hence is relevant to current plant performance. Assay by size has further enhanced the mass balancing exercise, and also the understanding of the various units within a concentrator.

The comminution and flotation simulation stage provides a means to quantify the effect of changes to complex circuits. Often, changes are difficult to justify without actually quantifying the potential benefit. It is proven that this approach, despite the need for caution and understanding of the software, offers a viable solution for such plant improvements.

10. References

- Alexander, D, Franzidis, J and Manlapig, E, 2003. Froth recovery measurement in plant scale flotation cells, *Mineral Engineering*, 16(11).
- Deglon, D, Egya-Mensah, D and Franzidis J, 2000. Review of hydrodynamics and gas dispersion in flotation cells on South African platinum concentrators, *Minerals Engineering*, 13(3):235-244.
- Gorain, B, 2000. Selection of cell operating conditions to optimize performance of flotation circuits with large cells, in *Proceedings Seventh Mill Operators' Conference*, pp 179-187 (The Australasian Institute of Mining and Metallurgy: Melbourne).
- Gorain, B, Franzidis, J and Manlapig E, 1999. The empirical prediction of bubble surface area flux in mechanical flotation cells from cell design and operating data, *Minerals Engineering*, 12(3):309-322.
- Harris, M C, Runge, K C, Whiten, W J and Morrison, R D, 2002. JKSimFloat as practical tool for flotation process design and optimization, in *Mineral Processing Plant Design, Practice, and Control*, Vol 1, pp 461-478 (Society for Mining, Metallurgy and Exploration: Littleton).
- Hernandez-Aguilar, J, Gomez, C and Finch, J, 2002. A technique for the direct measurement of bubble size distributions in industrial flotation cells, in *Proceedings 34th Annual Meeting of Canadian Mineral Processors* (ed: J Knesset), pp 389-402.
- Lynch, A, Johnson, N, Manlapig, E and Thorne, C, 1981. *Mineral and Coal Flotation Circuits: Their Simulation and Control*, pp 67-71 (Elsevier: Amsterdam).
- Power, A, Franzidis, J and Manlapig, E, 2000. The characterisation of hydrodynamic conditions in industrial flotation cells, in *Proceedings Seventh Mill Operators' Conference*, pp 243-255 (The Australasian Institute of Mining and Metallurgy: Melbourne).
- Vera, M, Mathee, Z, Franzidis, J et al. 2001, The modelling of froth zone recovery in batch and continuously operated laboratory flotation cells., in *International Journal of Minerals Processing* (Elsevier), pp 135-151.